

## Central-blocking safety device type CUKI-05

for rated voltage of controlling grid 500V  
with communications port RS485



Leakage central-blocking device type CUKI -05 is designed for controlling the earth resistance of a grid (including frequency converters) for rated three-phase voltage of 500V/50Hz with isolated star point on the transformer (system IT), to be used with equipment designed for working on the ground and in underground mining in mine face pits in non-explosive conditions, in conditions without methane explosion hazard and classified as A coal-dust explosion hazard

### TECHNICAL DATA:

ingress protection	IP54 or IP20
rated voltage of controlled grid	3x500V/50Hz
power supply rated voltage (Un)	24V/50Hz
supply voltage fluctuations	(0,8-1,2) x Un
max. capacitance to earth 1 circuit of grid or system for central/blocking unit	1/0,15 uF
tripping resistance of the central leaking unit	15kΩ±20%
tripping resistance of leakage blocking unit	25kΩ±20%
tripping time of the central leakage unit	<100ms lub <500ms*
weight	main unit ZG: 0,4kg coil unit ZD: 0,8kg indicator unit: 0,2kg test unit: 0,3kg artificial zero unit: 0,2kg

\* for grids with frequency converters

## CONSTRUCTION

Central-blocking safety device type CUKI-05/500V comprises of the following units:

- a/ main unit ZG
- b/ indicator unit ZW
- c/ coil unit ZD-500
- d/ artificial zero unit USZ
- e/ test unit ZP

## MODE OF OPERATION

CUKI-05/500V is powered with 24V/50Hz voltage through separation transformer. The measuring voltage causes current flow through earth resistance of the controlled grid. This current is measured by a microcontroller system and depending on the value the appropriate values of earth resistance are displayed. If the measured value of the earth resistance is lower than  $15k\Omega \pm 20\%$  the central unit and the executing relay of the safety device become actuated and a communicate EARTH CENTRAL UNIT is displayed. For check earth resistance outlet without voltage grid is realized by leakage blocking unit. If the measured value of the earth resistance is lower than  $25k\Omega \pm 20\%$  the blocking unit and the executing relay of the safety device become actuated and a communicate EARTH BLOCKING UNIT is displayed.

CUKI-05 is equipped with external communications port, which allows communicate through RS485 bus with using of communications protocol MODBUS RTU. Through remote access to internal register of CUKI-05/500V it is possible to execute many operations f.e.: reading identification data of safety device, reading of present and emergency states of safety device, reading memory of registered states and remotely control of safety device.

## SCHEMATIC DIAGRAM

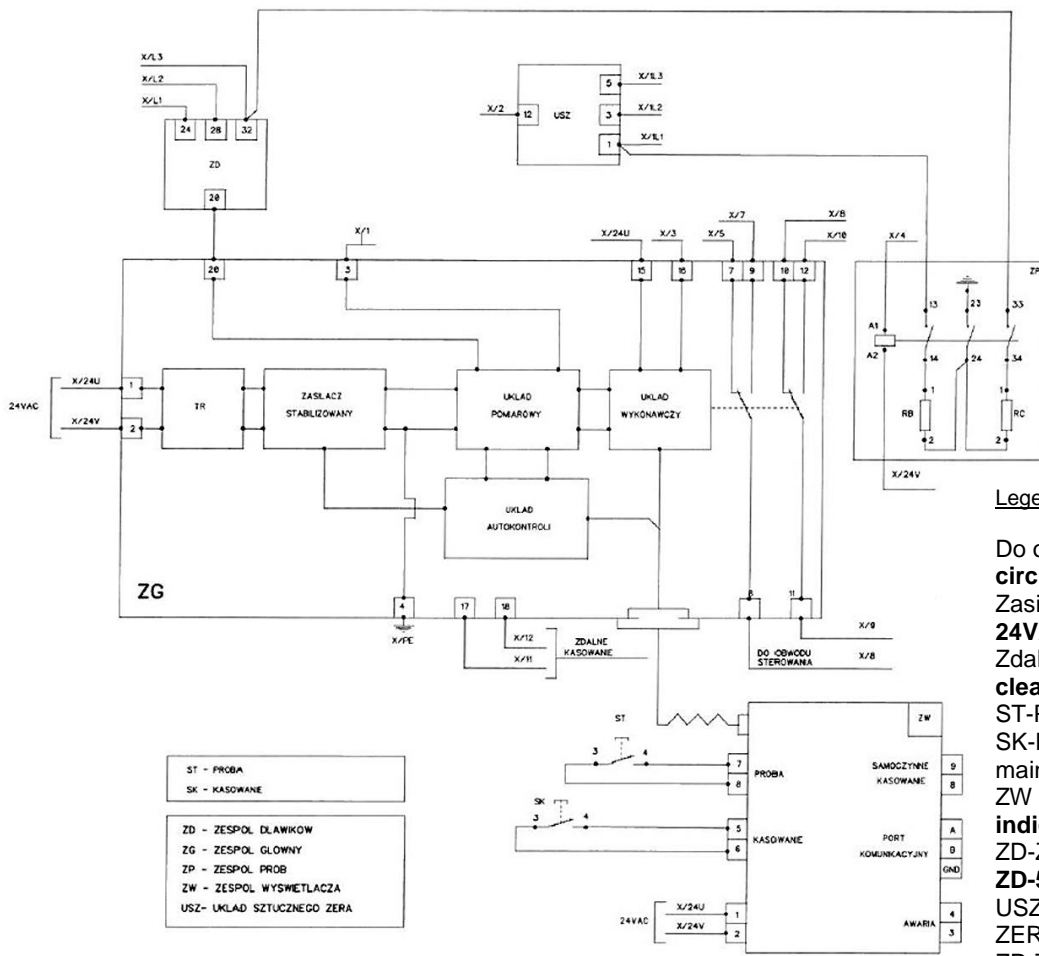

Orders should be submitted in writing or by fax to the address:

**Instal-Service PL**

Spółka z ograniczoną odpowiedzialnością  
Spółka komandytowa

58-506 Jelenia Góra, ul. Wrocławska 15a  
tel. (+48 075) 64-57-950  
fax. (+48 075) 64-57-951  
e-mail: instal@instal-service.pl